

Creating the Digital Opportunity in Oregon



Technology in the Northwest

Over 66 million, or a quarter of America's population, is online everyday.

Pacific Northwest is the most wired region in America.

- 66% of Northwest adults use the Internet
- 47% of families earning under \$30,000 use the Internet, compared with the national average of 38%



Among households, computer and Internet access at home continues to increase although at a slower rate.

- 88 percent of households with a home computer can access the Internet from that computer. Nearly half (45%) of those with Internet access have high-speed access.

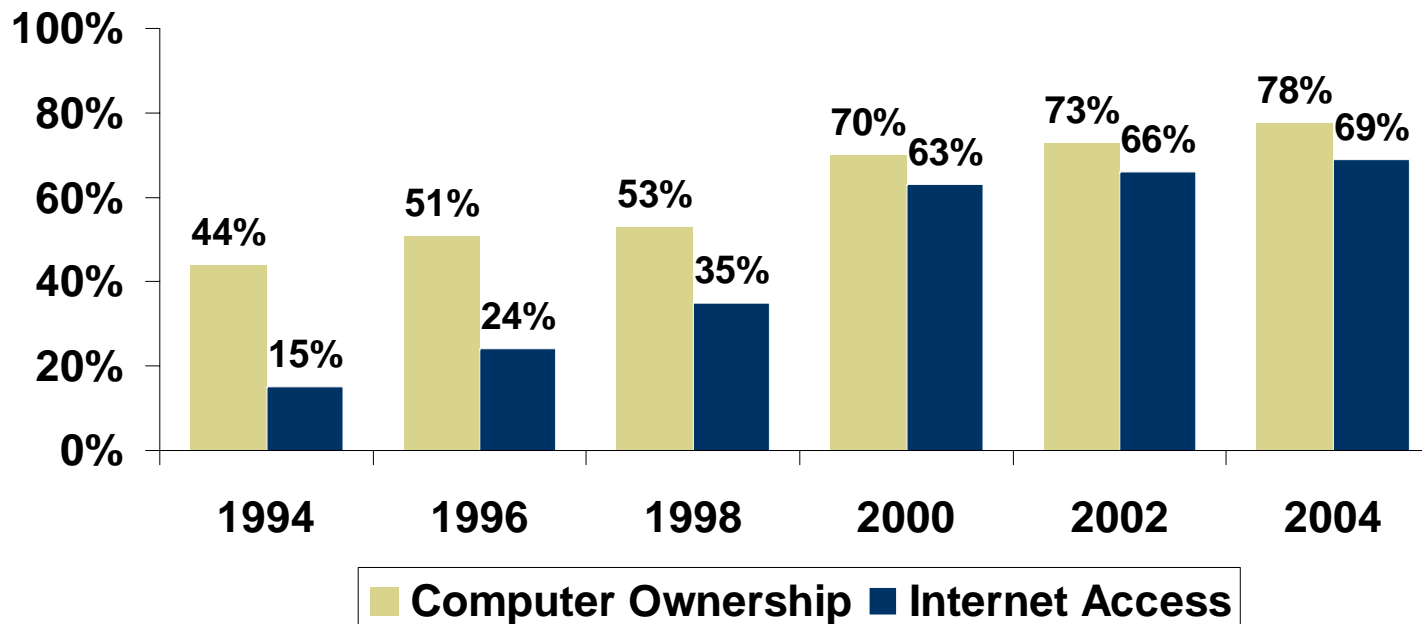
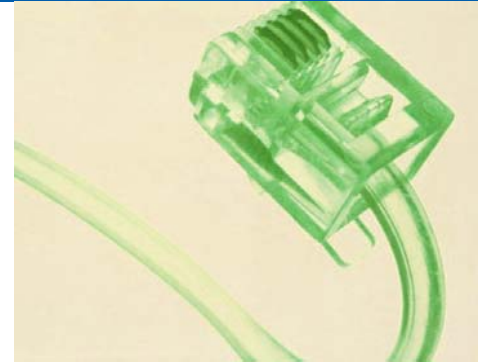

One Economy Corporation maximizes the potential of technology for 27 million low and moderate income people to join the economic mainstream.



Our Accomplishments

One Economy is a national organization

- **Work in 22 cities**
- **Serve 620,000 visitors on the Beehive each month**
- **Wired \$2B of affordable housing**
- **Changed public policy to support integration of high-speed Internet access in housing in 19 states**



One Economy's Strategy

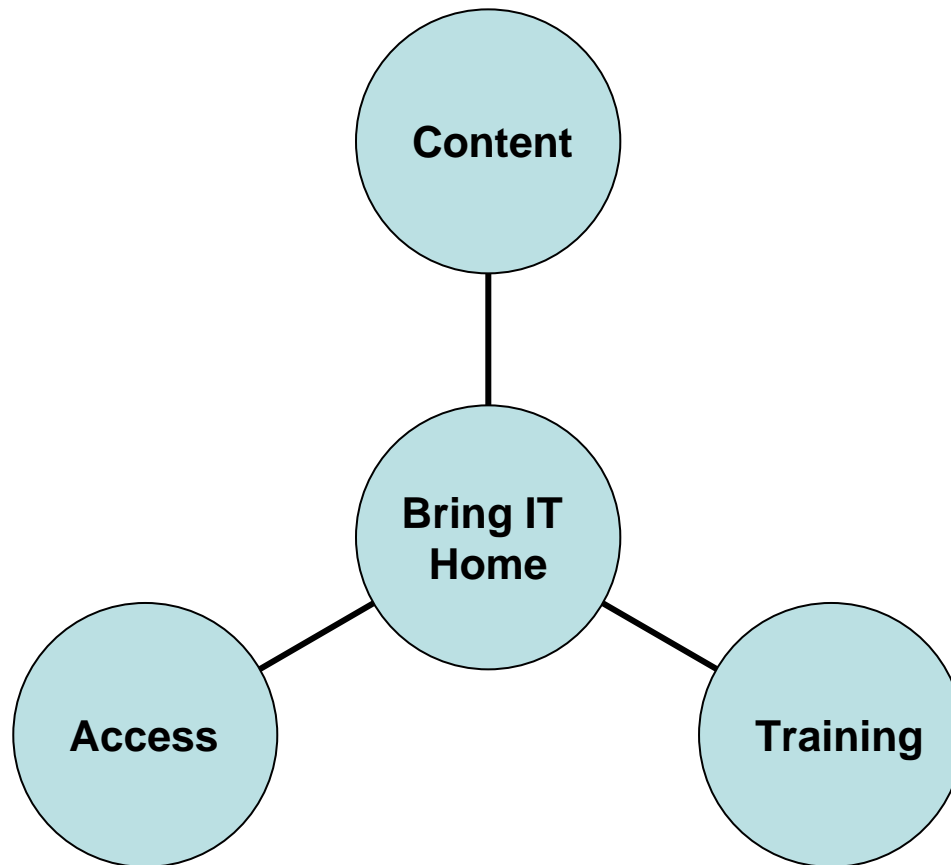

Creating Access

One Economy is a national provider of technology services to the owners of affordable housing.

Our primary purpose is to design and implement high-speed, low-cost Internet access solutions for clients to create a distribution channel for helpful online content.





THE
BRING IT HOME
CAMPAIGN

A national education initiative to assist state-level public policy makers on how to bring high-speed Internet connectivity to affordable housing.

// Policy changes in 27 states and one city (Portland)

// National partners include CISCO, Microsoft, Intel, Qwest, AOL Time Warner & 12 other partners.





Our Services

// Free technology design of the most cost effective network options

// Installation of data networks, including security, CATV, phones and access control through our nonprofit subsidiary at below market costs.

// Providing networking equipment donated by Cisco.

// Maintenance and support services.

// Computer options through bulk, discounted purchases with Dell or Gateway.

= 4,500+ units wired in 2004



Creating Access: Shared Data Networks

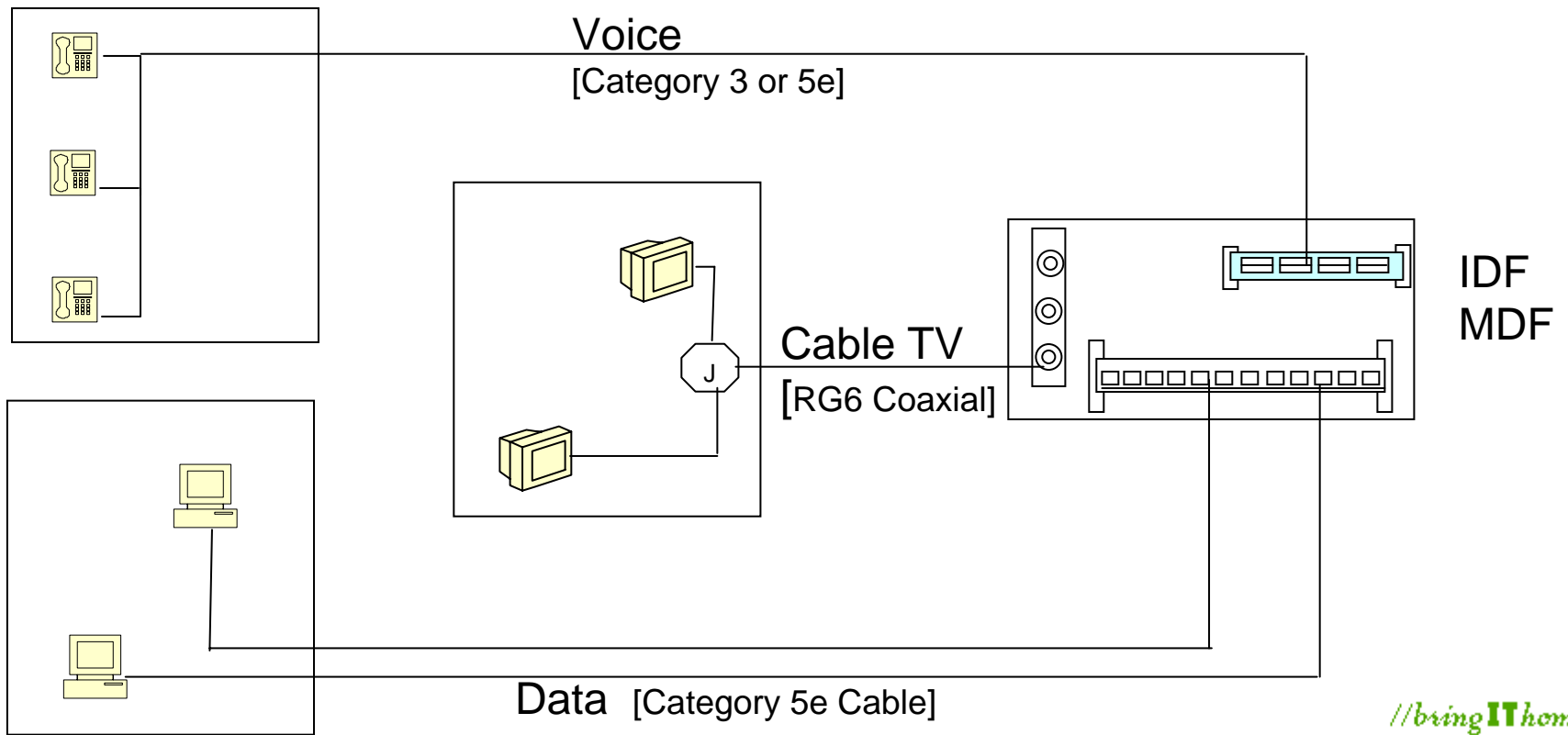

The Beehive (www.thebeehive.org)

Powering A Local Connection

The Beehive is a content-rich, multilingual site to provide users with resources on the things that matter most in their lives –

money, health, jobs, school & family

Local Content = Local Connections



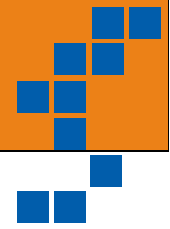

Employment
Entrepreneurship

Housing
Childcare
Health Insurance
Managing Money
Public Benefits,
etc.

Increased Income

+ Necessary Supports for Work & Family

Individual Economic Development





PORTLAND, OREGON

- MONEY 
- HEALTH 
- SCHOOL 
- JOBS 
- FAMILY 
- About Insurance
- Find Child Care
- Computer Support
- Government
- Housing
- Legal/Immigration

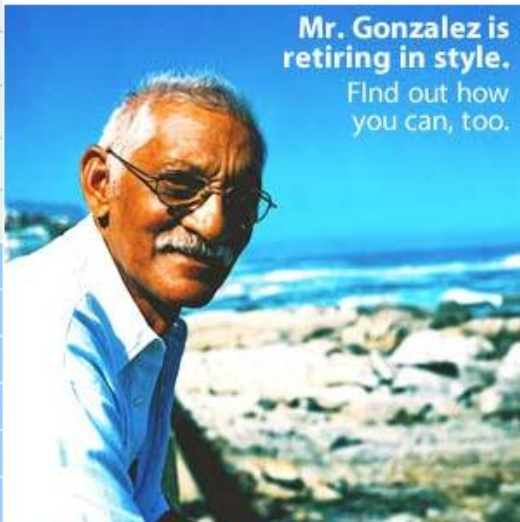

 64°
[Get extended forecast](#)



Portland Impact:
[Providing the support and services you need](#)

Portland Housing Center:
[Get Help Buying a Home](#)

the Entrepreneur's Center 



Get small business help and resources.

Multilingual Free Email

Connecting to local resources

Monthly Updates

What Can I Help You Find?

Type your question in the white box, and click "ask."

Ask a question  

In the News:

BofA expands environmental policies

Business Journal of Portland

[more news, sports & more](#)

THE buzz THE BEEHIVE'S FREE MONTHLY EMAIL NEWSLETTER
The best of the Beehive emailed to you each month...

Email: Zip Code:





Health: Women

[Healthy Living](#)

[OB/GYN](#)

[Sickness and Disease](#)

[Pregnancy](#)

[Depression and Mental Health](#)

[Abuse](#)



Do It

Exercising just three days a week for a half an hour will help keep your heart healthy and your weight in balance.

Chatline

Find out about the risks of diet drugs with Dr. Lisa Martin in Thursday's Living Lean chat at 3pm EST.

Need help finding something?

Poll Question:

Which is most important for your health?

- Exercise
- Eating Right

Did you know...?

Women are three times as likely as men to be depressed where as men are five times as likely to commit suicide. Almost 20 percent of Americans have depression, most without knowing it.

Need help? [Click here.](#)

Topics related to the experiences of lower-income families

Interactive content



Portland, Oregon

Rob Bole ([Sign Out](#))

[Home Page](#)

[Money](#)

[Health](#)

[School](#)

[Jobs](#)

[Family](#)

[Email](#)

[Local](#)

[En Español](#)

Career Coach

Imagine a Career

Take a career match quiz or browse lots of exciting careers that fit you best.

Build Your Career

Find a job right away in your field or find out how to get the training and education you need.

Do what you can, with what you have, where you are.
-- Theodore Roosevelt



- [Job Search](#)
- [Write a Resume](#)
- [Get Your GED](#)
- [Go to School](#)
- [See All Jobs Topics](#)

Need help finding something?

Search

Guide for career path for low-income users

Nonprofit interface to manage user communications

[Home Page](#) [Site Map](#) [Help/Feedback](#) [About Career Coach](#)

Created in partnership with



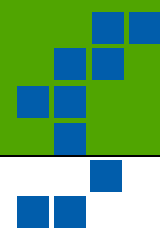

Beyond eGovernment: Implications for State Policy/Practice

- 1. Include the voice of the citizenry in eGovernment projects**
- 2. Increase use of the Internet to provide services & have agencies work collaboratively**
- 3. Engage in long-term State of Oregon technology planning**



“One Economy and the Beehive are connecting the poor in a way that unleashes their potential and it just might spark their imagination.”

Rey Ramsey
CEO of One Economy



Robert Bole
Vice President, Northwest
One Economy Corporation

503.282.2824
rbole@one-economy.com